

BANC MODULAIRE SERPENTIN KAA

CARACTERISTIQUES TECHNIQUES :

Structure en acier traité anticorrosion et poudré anti-uv
 Compact en HPL finition lame
 Haute qualité et résistant
 Design et modulable à l'infini
 Couleur de la structure : Gris anthracite mat RAL 7016
 Couleurs disponibles pour le compact : Chêne clair, Pin Tyrol ou Teck
 A fixer en 6 points d'ancrage (kit de fixation non fourni)
 Livré non monté



Finition compact Teck

DIMENSIONS :

L. 2040 x l. 746 x H. 420 mm

DESIGNATION	REFERENCE
Banc modulable	B7031

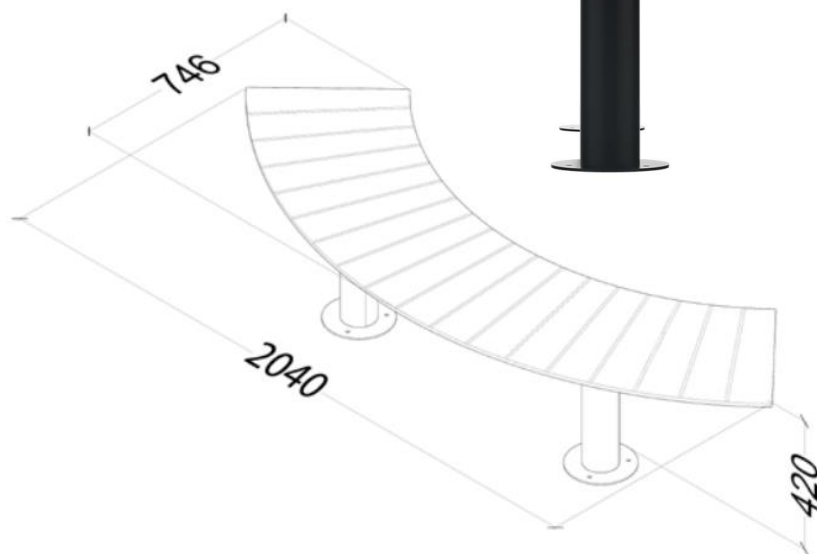

Finition compact Pin Tyrol



Finition compact Chêne clair



EXEMPLES DE REALISATION

